

CHAPTER 5

VECTOR TRANSFORMATIONS

Now that we've talked about vectors, they're going to give us a whole new way to look at parametric equations. This is because we can always associate a position vector, a vector whose initial point is at the origin, with the corresponding point that it terminates at. For example, the point $(2,3)$ in two dimensions can be described either by saying $x=2$ and $y=3$, or by giving the position vector $\vec{r} = 2\hat{i} + 3\hat{j}$. Now let's apply this to something like a circle of radius 1 with center at the origin.

Recall that we saw previously that a good parametrization for the unit circle is,

$$\begin{aligned}x &= \cos t \\y &= \sin t \\0 &\leq t \leq 2\pi\end{aligned}$$

We can now write this as a vector-value function as,

$$\begin{aligned}\vec{r}(t) &= \cos(t)\hat{i} + \sin(t)\hat{j} \\0 &\leq t \leq 2\pi\end{aligned}$$

and the graph is the same circle we saw before. Also, if you want a larger circle, just multiply $\vec{r}(t) = \cos(t)\hat{i} + \sin(t)\hat{j}$ by whatever you would like the radius to be.

Vector Transformations

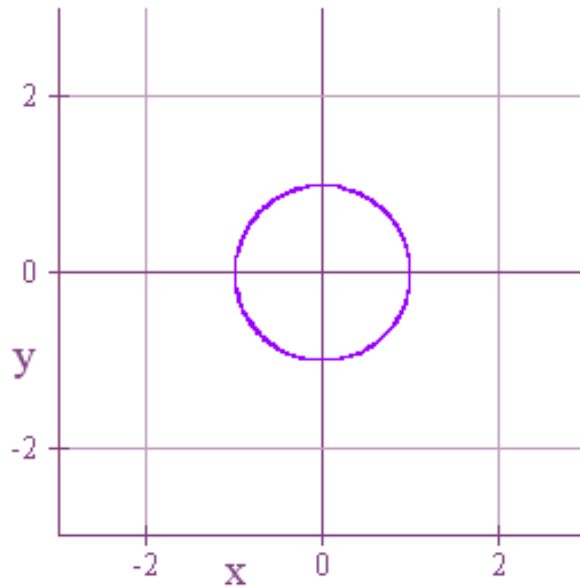

If we want to now graph this unit circle in three dimensions, the vector representation again tells us how to do it. All we need to do is set the \hat{k} -component equal to zero.

$$\vec{r}(t) = \cos(t)\hat{i} + \sin(t)\hat{j} + 0\hat{k}$$
$$0 \leq t \leq 2\pi$$

And the end result is a circle in 3-dimensional space.

Vector Transformations

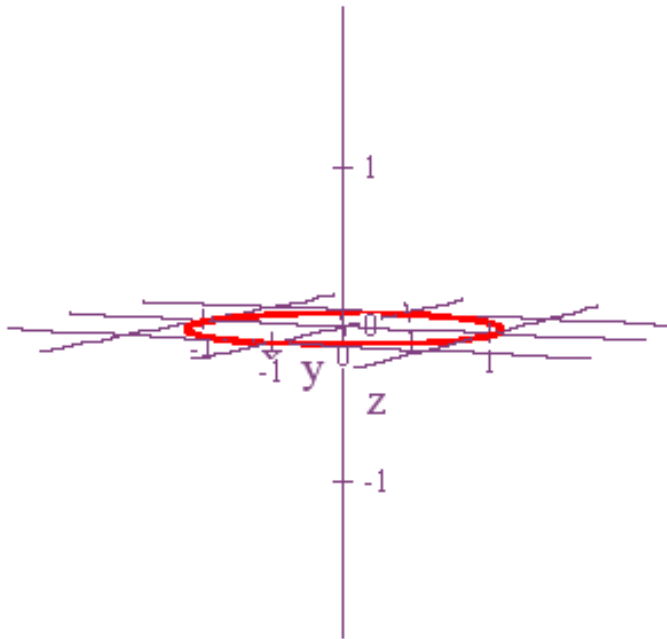

What if we now want our circle in the yz -plane instead of the xy -plane? No problem!

Just make your \hat{i} -component zero and move your cosine and sine functions to the \hat{j} and \hat{k} -components.

$$\begin{aligned}\vec{r}(t) &= 0\hat{i} + \cos(t)\hat{j} + \sin(t)\hat{k} \\ 0 \leq t \leq 2\pi\end{aligned}$$

Vector Transformations

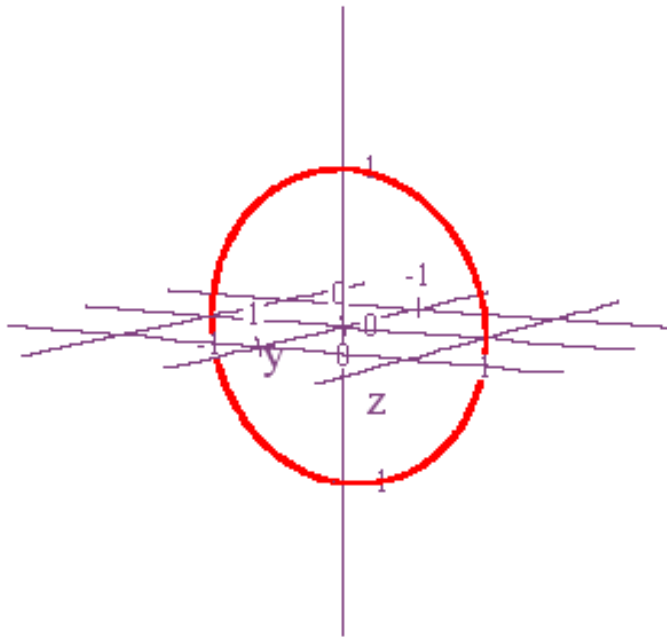

Now suppose we want to shift this circle 1 unit along the positive y -axis and 1 unit along the positive z -axis. Again, there is no difficulty if we use vectors. We just need to take the vector $\vec{u} = \hat{j} + \hat{k}$ and add it to the vector \vec{r} .

$$\vec{r} + \vec{u} = 0\hat{i} + (\cos(t) + 1)\hat{j} + (\sin(t) + 1)\hat{k}$$
$$0 \leq t \leq 2\pi$$

Vector Transformations

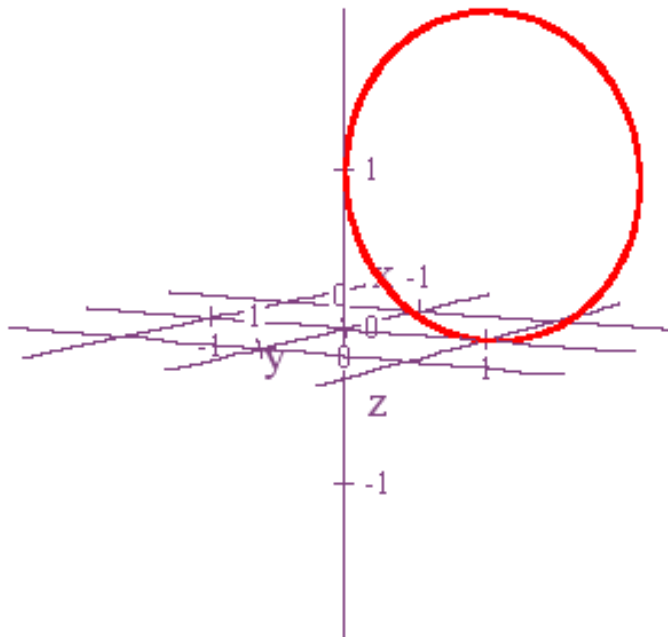

From these examples you might correctly deduce that to create a circle in any plane, all you need are two unit vectors which are perpendicular. For example, let's graph the unit circle with center at the origin that lies in the plane $y = -x$. For our unit vectors we could use $\vec{v} = \hat{k}$ and $\vec{w} = \cos \frac{3\pi}{4} \hat{i} + \sin \frac{3\pi}{4} \hat{j} = -\frac{\sqrt{2}}{2} \hat{i} + \frac{\sqrt{2}}{2} \hat{j}$. Our circle, written in vector form, will then be,

$$\vec{r}(t) = \cos(t) \vec{v} + \sin(t) \vec{w} = -\frac{\sqrt{2}}{2} \sin(t) \hat{i} + \frac{\sqrt{2}}{2} \sin(t) \hat{j} + \cos(t) \hat{k}$$
$$0 \leq t \leq 2\pi$$

Vector Transformations

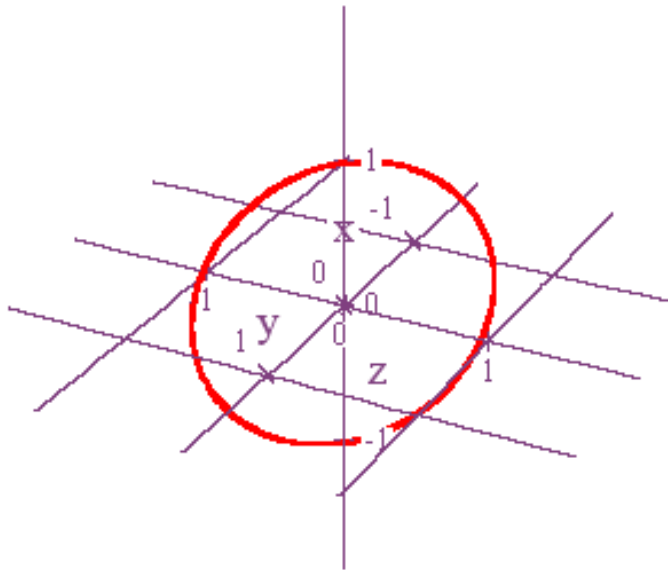

I love it when the magic works! If we now want to shift the whole thing 1 unit in the direction of the vector \vec{w} , then just add the unit vector \vec{w} to \vec{r} .

$$\vec{r}(t) + \vec{w} = \left(-\frac{\sqrt{2}}{2} \sin(t) - \frac{\sqrt{2}}{2} \right) \hat{i} + \left(\frac{\sqrt{2}}{2} \sin(t) + \frac{\sqrt{2}}{2} \right) \hat{j} + \cos(t) \hat{k}$$
$$0 \leq t \leq 2\pi$$

Vector Transformations

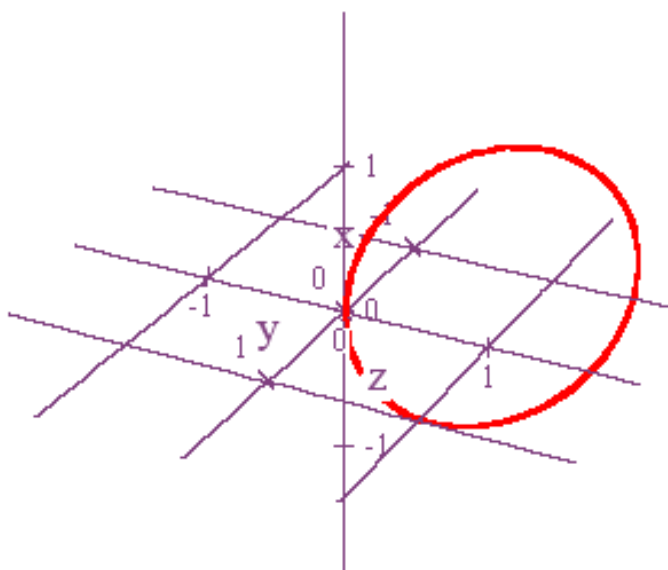

And again it worked! Now let's take something a little more challenging. Let's see if we can use a vector-valued function to come up with parametric equations for a cycloid. What's a cycloid? Well, if you are riding a bicycle in a straight line, and if you put a red dot on some particular point on your tire, then the path that red dot traces out as you go along is called a cycloid. Mathematicians thought about cycloids a lot a few hundred years ago. Personally, I don't care about them at all, but it does make for an interesting example. So let's suppose we have a circle of radius r with center at $(0, r)$, and let's also suppose that we've marked our circle with a red dot at the point $(0, 0)$.

Vector Transformations

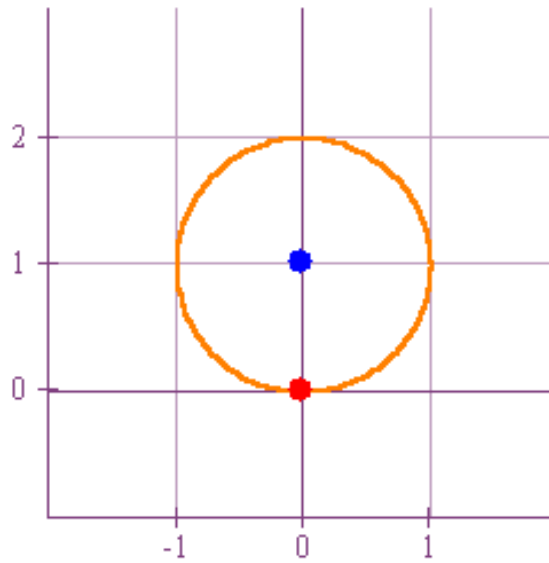

We now ask ourselves what path the red dot will trace out as we roll the circle right or left. The path that is traced is what we call a cycloid.

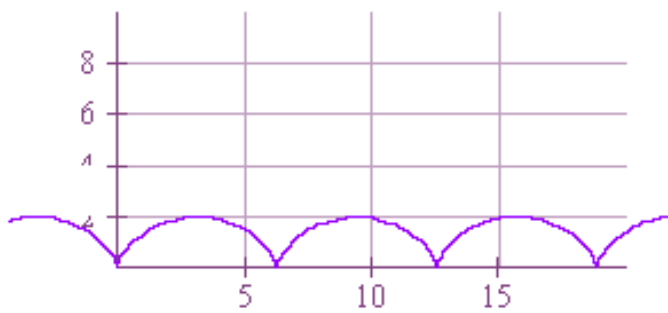

Vector Transformations

Now let's suppose that we've rolled our circle a little to the right. Then we might get a picture like the one below.

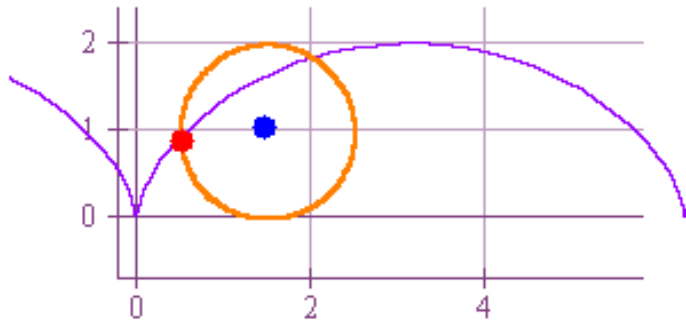

What we want to do is figure out the location of the red dot, and it turns out that this is not that hard to do if we describe everything in terms of vectors. To arrive at the position of the red dot, all we need to do is add three vectors together.

Vector Transformations

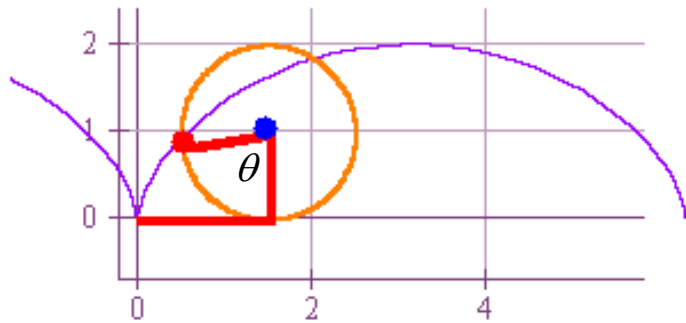

The first vector that we'll call \vec{r}_1 starts at the origin and extends horizontally to the right until it meets the circle. If you think of the circle “unwrapping” as it moves along, then the length of \vec{r}_1 is the same as the length of the arc of the circle corresponding to the angle θ . From trigonometry we know that the length of this arc is $r\theta$, the product of the radius and the angle. Because of the direction of movement, we set $\vec{r}_1 = r\theta\hat{i}$. The next vector, \vec{r}_2 , points straight up and has length r . Therefore, $\vec{r}_2 = r\hat{j}$. The third vector, which goes from the center of the circle to a point on the circle, is a little trickier. However, imagine moving this vector so that its initial point is at the origin. If we do that, then the angle made with the positive x -axis would be $\frac{3\pi}{2} - \theta$. Hence, we should define our third vector as,

Vector Transformations

$$\begin{aligned}\vec{r}_3 &= r \cos\left(\frac{3\pi}{2} - \theta\right) \hat{i} + r \sin\left(\frac{3\pi}{2} - \theta\right) \hat{j} \\ &= r \left[\cos\left(\frac{3\pi}{2}\right) \cos(\theta) + \sin\left(\frac{3\pi}{2}\right) \sin(\theta) \right] \hat{i} + r \left[\sin\left(\frac{3\pi}{2}\right) \cos(\theta) - \cos\left(\frac{3\pi}{2}\right) \sin(\theta) \right] \hat{j} \\ &= -r \sin(\theta) \hat{i} - r \cos(\theta) \hat{j}\end{aligned}$$

Hence,

$$\vec{r}(\theta) = \vec{r}_1(\theta) + \vec{r}_2(\theta) + \vec{r}_3(\theta) = (r\theta - r \sin(\theta)) \hat{i} + (r - r \cos(\theta)) \hat{j}$$

Thus, the cycloid is defined by the following parametric equations.

$$\begin{aligned}x &= r(\theta - \sin \theta) \\ y &= r(1 - \cos \theta) \\ -\infty &< \theta < \infty\end{aligned}$$

Is that cool or what! In our graphs above, we used $r = 1$ for simplicity. Nonetheless, you can see how thinking terms of vectors greatly simplified the problem.

Up until now we've looked only at parametric equations or vector-valued functions of a single variable, and the result has always been a curve in space. However, there's no reason why we can't expand our explorations to equations involving two variables, and when we do so, we'll generally get surfaces instead of curves. And actually, you've already seen parametric equations involving more than one variable. Just think back to the equations we set up for converting from cylindrical and spherical coordinates back to rectangular coordinates. These were each parametric equations with two parameters. In particular, if we want to describe a sphere of radius $\rho = 2$, then our parametric equations are,

Vector Transformations

$$x = \rho \sin \varphi \cos \theta = 2 \sin \varphi \cos \theta$$

$$y = \rho \sin \varphi \sin \theta = 2 \sin \varphi \sin \theta$$

$$z = \rho \cos \varphi = 2 \cos \varphi$$

$$0 \leq \varphi \leq \pi$$

$$0 \leq \theta \leq 2\pi$$

Or course, we could also write this in vector form as,

$$\vec{r}(\varphi, \theta) = (2 \sin \varphi \cos \theta) \hat{i} + (2 \sin \varphi \sin \theta) \hat{j} + (2 \cos \varphi) \hat{k}$$

$$0 \leq \varphi \leq \pi$$

$$0 \leq \theta \leq 2\pi$$

And if we graph these equations, then sure enough we get a sphere!

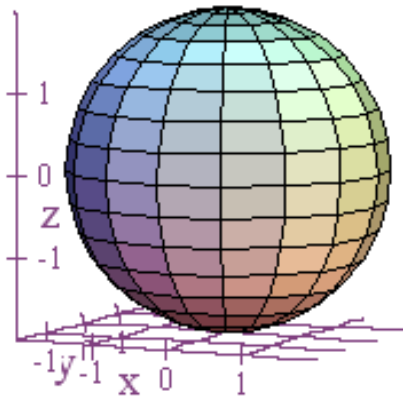

Vector Transformations

As we did previously, if we want to move this sphere to a different location, we just need to add the appropriate vector to it. For example, if we set $\vec{u} = 2\hat{k}$, then $\vec{r}(\varphi, \theta) + \vec{u}$ will shift our sphere 2 units upwards.

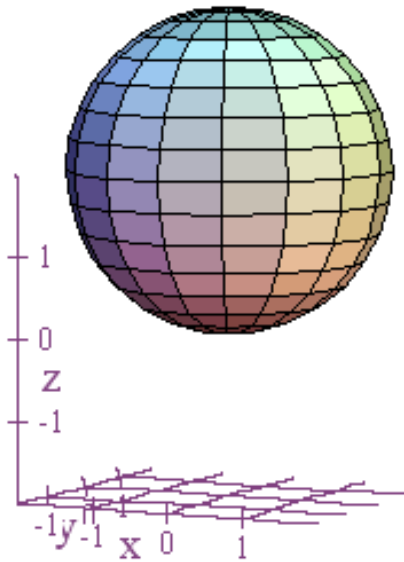

Now let's look at how we can construct a plane using parametric equations with two variables. We'll do it all from scratch starting with three distinct points $P = (6, 1, 1)$, $Q = (-2, -3, 5)$, and $R = (0, 4, 2)$. If we plot these points, we get something like the following.

Vector Transformations

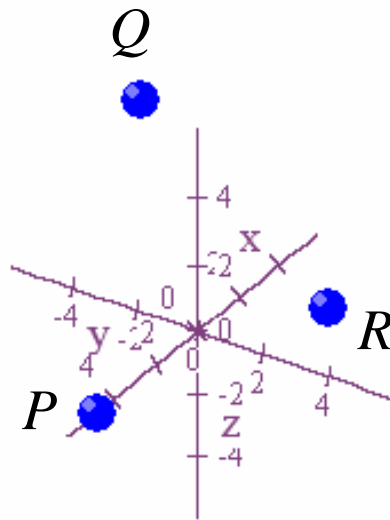

We can now use parametric equations to draw line segments representing the displacement vectors \overline{PQ} and \overline{PR} .

\overline{PQ} :

$$x = 6 - 8t$$

$$y = 1 - 4t$$

$$z = 1 + 4t$$

$$0 \leq t \leq 1$$

\overline{PR} :

$$x = 6 - 6t$$

$$y = 1 + 3t$$

$$z = 1 + t$$

$$0 \leq t \leq 1$$

Vector Transformations

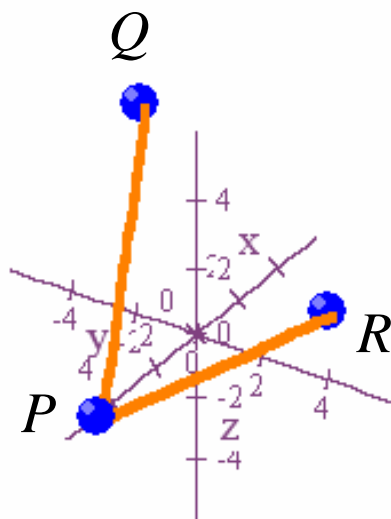

Remember, too, that if we set $t=1$, then we can write these vectors and the location of point $P=(6,1,1)$ as,

$$\vec{r} = \langle 6, 1, 1 \rangle$$

$$\vec{u} = \langle -2, -3, 5 \rangle$$

$$\vec{v} = \langle 0, 4, 2 \rangle$$

Furthermore, it should be clear from the diagram above that the vectors \vec{u} and \vec{v} define a plane, and we can reach any point in this plane by starting at P and adding on scalar multiples of \vec{u} and \vec{v} . In other words, if we let s and t be our parameters, then $\vec{w} = \vec{r} + s \cdot \vec{u} + t \cdot \vec{v}$ defines a plane. If we write this out parametrically, we get:

$$x = 6 - 2s$$

$$y = 1 - 3s + 4t$$

$$z = 1 + 5s + 2t$$

$$-\infty < s < \infty$$

$$-\infty < t < \infty$$

And here's our plane!

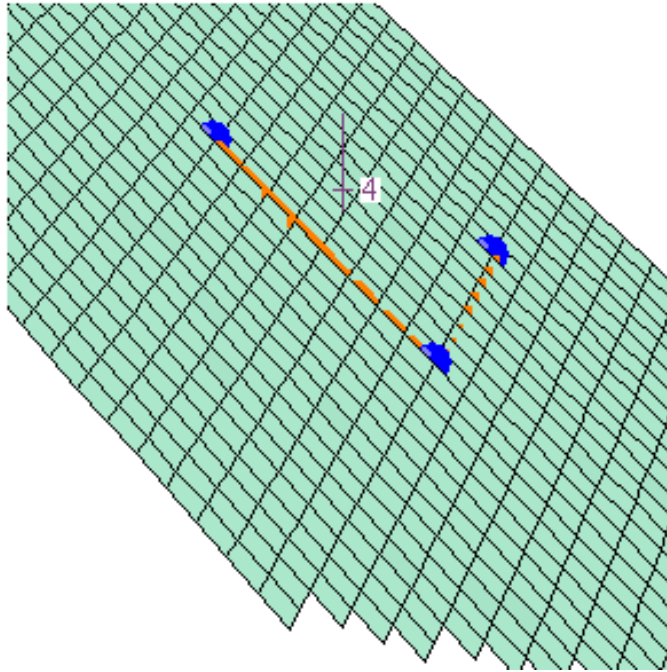

The axes are hidden by our plane, but we can clearly see that it contains our three points and the displacement vectors \overline{PQ} and \overline{PR} . Thus, we now have at least a couple of ways to construct a plane using three points. We can use the vectors \overline{PQ} and \overline{PR} to help us set up parametric equations in two variables for the plane, or we could get a normal vector by taking the cross product of \overline{PQ} and \overline{PR} , and then proceeding as we did before to get an equation in the form $Ax + By + Cz + D = 0$.

Another surface worth examining is a donut shaped object called the torus. I, however, like to just refer to it as the bagel. Here's a picture of the object we're going to try to create

Vector Transformations

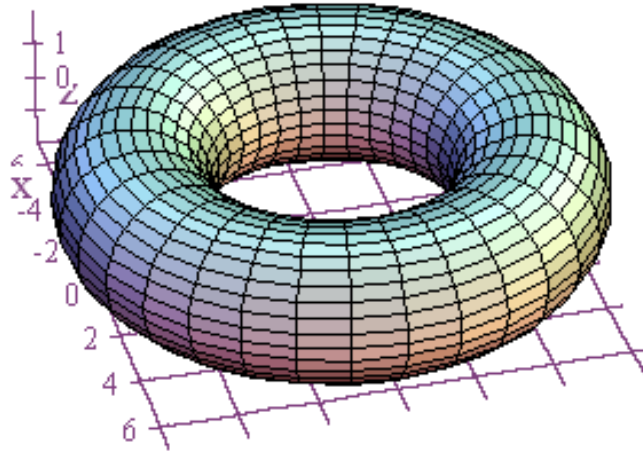

The basic idea is that we'll create parametric equations for a circle, and then rotate that circle around the z -axis to make the bagel. So, to begin, imagine that we fix an angle θ in the xy -plane that is measured with respect to the positive x -axis. This angle will define a plane that is orthogonal to the xy -plane, and we want to put our circle in this plane. To do this, recall that we need two unit vectors that are perpendicular to one another. Fortunately, it turns out that it is easy to find two such vectors. For one of the vectors we can use $\vec{u} = \cos\theta\hat{i} + \sin\theta\hat{j}$. This vector is a unit vector, and it lies in both the xy -plane and the plane defined by our angle θ . For the second vector we can use $\vec{v} = \hat{k}$. This unit vector points straight up, and is perpendicular to \vec{u} . In terms of these vectors, the vector-valued function $\cos\varphi\vec{u} + \sin\varphi\vec{v}$, $0 \leq \varphi \leq 2\pi$, will now define a circle of radius 1. If, however, we want

Vector Transformations

our circle to be of radius 2, then we just need to multiply each component by 2 to get $2\cos\varphi\vec{u} + 2\sin\varphi\vec{v}$, $0 \leq \varphi \leq 2\pi$. At this point, however, there is one small problem.

The center of this circle of radius 2 is at the origin, and we need to offset it from the origin before we rotate it around the z -axis. Fortunately, we have a unit vector pointing in the direction we want to offset it. Namely, \vec{u} . So if we want to move our circle 5 units in the direction of \vec{u} , all we need to do is add $5\vec{u}$ to the previous result. This will give us $2\cos\varphi\vec{u} + 2\sin\varphi\vec{v} + 5\vec{u}$, $0 \leq \varphi \leq 2\pi$. To now finish constructing the bagel (torus), all we need to do is rotate this around the z -axis by letting θ vary from 0 to 2π . Our final vector-valued function is,

$$\begin{aligned}\vec{r}(\theta, \varphi) &= 2\cos\varphi\vec{u} + 2\sin\varphi\vec{v} + 5\vec{u} \\ &= 2\cos\varphi\cos\theta\hat{i} + 2\cos\varphi\sin\theta\hat{j} + 2\sin\varphi\hat{k} + 5\cos\theta\hat{i} + 5\sin\theta\hat{j} \\ &= (2\cos\varphi\cos\theta + 5\cos\theta)\hat{i} + (2\cos\varphi\sin\theta + 5\sin\theta)\hat{j} + 2\sin\varphi\hat{k}\end{aligned}$$

From this, we can see that our parametric equations should be,

$$\begin{aligned}x &= 2\cos\varphi\cos\theta + 5\cos\theta \\ y &= 2\cos\varphi\sin\theta + 5\sin\theta \\ z &= 2\sin\varphi \\ 0 &\leq \varphi \leq 2\pi \\ 0 &\leq \theta \leq 2\pi\end{aligned}$$

Again, here is the wonderful graph that results!

Vector Transformations

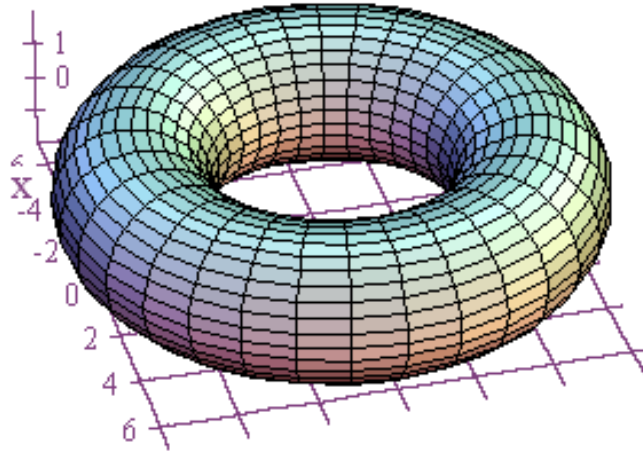

A variation of what we just did can be used to create, for example, solids of revolution about the x -axis. For this example, let's suppose that we want to rotate the curve $y = x^2$ about the x -axis. Then let's begin by expressing this curve parametrically as $x = t$, $y = \sqrt{t}$. Next, we need to create circular cross-sections that will be parallel to the xz -plane. Fortunately, we can use our unit vectors \hat{j} and \hat{k} for this purpose, and, hence, $\vec{v} = \cos\theta \hat{j} + \sin\theta \hat{k}$ will give us a unit circle parallel to the xz -plane. However, we don't want the radius of our circle to always be 1. We want it to be equal to our function value as we move along the x -axis. In particular, when $x = t$, we want the radius of our circular cross-section to be \sqrt{t} . Thus, let's set $\vec{v} = \sqrt{t} \cos\theta \hat{j} + \sqrt{t} \sin\theta \hat{k}$. If we now set $\vec{w} = t\hat{i}$, then we'll get the correct equation for

Vector Transformations

the solid of revolution by simply adding \vec{v} and \vec{w} together. In plain English, go out t units on the x -axis, draw a circle of radius \sqrt{t} , and then repeat with different values of t . Here's the final equation and the graph that results.

$$\vec{r}(t, \theta) = t\hat{i} + \sqrt{t} \cos \theta \hat{j} + \sqrt{t} \sin \theta \hat{k}$$

$$x = t$$

$$y = \sqrt{t} \cos \theta$$

$$z = \sqrt{t} \sin \theta$$

$$0 \leq \theta \leq 2\pi$$

$$0 \leq t \leq 2$$

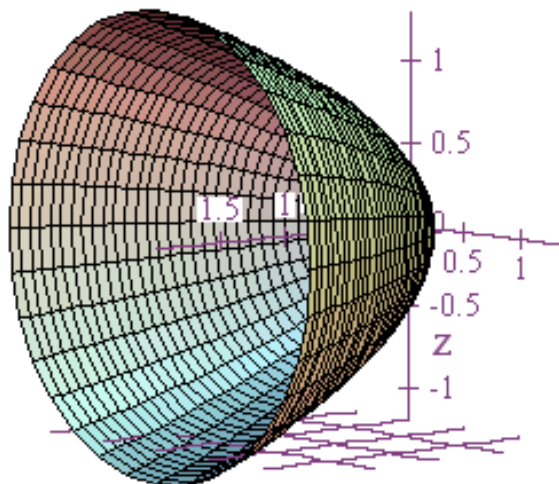

Now let's look at a more unusual graph described by parametric equations, namely the Möbius strip. This is an object formed by taking a strip of paper, giving it a half-twist, and then connecting the ends. The resulting surface looks like this.

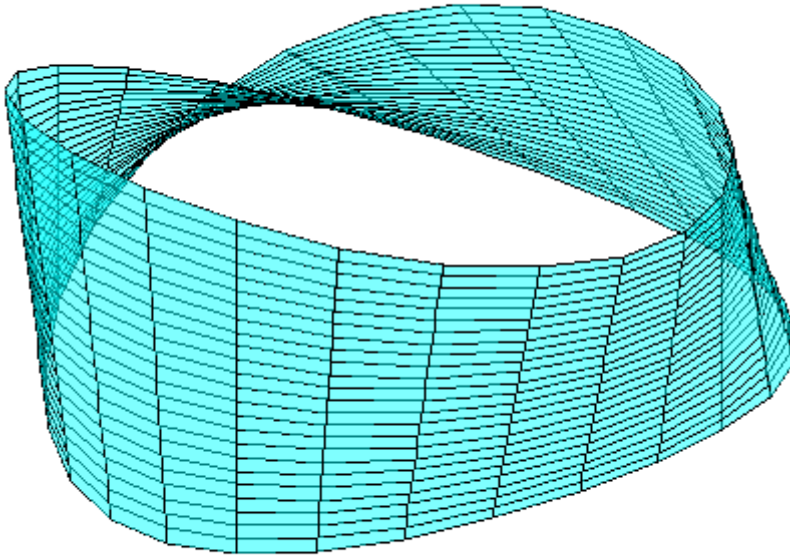

This is an example in mathematics of what we call a one-sided surface. In other words, if you trace a line lengthwise along this object, then you'll see when done that you've traced the line on both of what you may have thought were two different sides. A better way to convince yourself that this surface is different is to cut it in half lengthwise along the line you traced. When you finish this, you'll discover that you have just one long twisted piece instead of two pieces. If nothing else, this should convince you that it doesn't have two sides. Otherwise, when we cut it in half we should get two pieces! The parametric equations for the above Möbius strip are as follows,

Vector Transformations

$$x = \cos u + v \sin\left(\frac{u}{2}\right) \cos u$$

$$y = \sin u + v \sin\left(\frac{u}{2}\right) \cos u$$

$$z = v \cos\left(\frac{u}{2}\right)$$

$$0 \leq u \leq 2\pi$$

$$-0.5 \leq v \leq 0.5$$

An even more intriguing object is the Klein bottle which is pictured below.

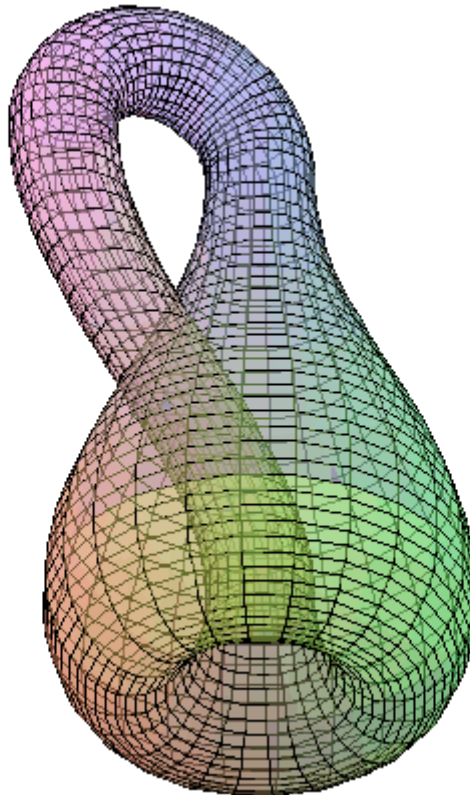

Technically, this is a surface that takes a twist through a fourth dimension in order to create an object whose inside is the same as its outside. Also, while this may seem a

Vector Transformations

little fanciful, isn't that the way we are? In other words, we normally tend to think of ourselves as a ghost in a machine whose thoughts and perceptions occur on the inside in response to what goes on on the outside. However, every time we have a thought or emotion, doesn't that register as brain activity on the outside, in the physical world? In this sense, we can't really make a clear distinction between our inside and our outside, and that is why we are like living Klein bottles. Everything that occurs "inside" us has its corresponding marker "outside" of us back in the physical world. By the way, mathematicians refer to both the Möbius strip and the Klein bottle as nonorientable figures. In other words, we can't give either object any sort of orientation with respect to side. In each object, what appear to be separate sides are really the same. With most things we encounter in life, we can assign some clear orientation like north, south, east, or west, or democrat or republican, but with these objects, the surfaces lack the appropriate orientations that are needed to create separation between sides. Consequently, I often think that in order to transcend separation and become one with anything, you first need to become a little disoriented!

To generate the nice image of the Klein bottle above, I had to use four sets of parametric equations and then combine the images when done. For future reference, here are my equations.

Vector Transformations

Klein1:

$$x = (2.5 + 1.5 \cos v) \cos u$$

$$y = (2.5 + 1.5 \cos v) \sin u$$

$$z = 3v$$

$$0 \leq u \leq 2\pi$$

$$0 \leq v \leq \pi$$

Klein2:

$$x = 2 - 2 \cos v + \sin u$$

$$y = \cos u$$

$$z = 3v$$

$$0 \leq u \leq \pi$$

$$0 \leq v \leq \pi$$

Klein3:

$$x = 2 + (2 + \cos u) \cos v$$

$$y = \sin u$$

$$z = 3\pi + (2 + \cos u) \sin v$$

$$0 \leq u \leq \pi$$

$$0 \leq v \leq \pi$$

Klein4:

$$x = (2.5 + 1.5 \cos v) \cos u$$

$$y = (2.5 + 1.5 \cos v) \sin u$$

$$z = -2.5 \sin v$$

$$0 \leq u \leq \pi$$

$$0 \leq v \leq \pi$$

Vector Transformations

Now let's look at something quite different. We'll start, though, with some parametric equations that look very innocuous at first glance.

$$x = s + t$$

$$u = s - t$$

$$z = st$$

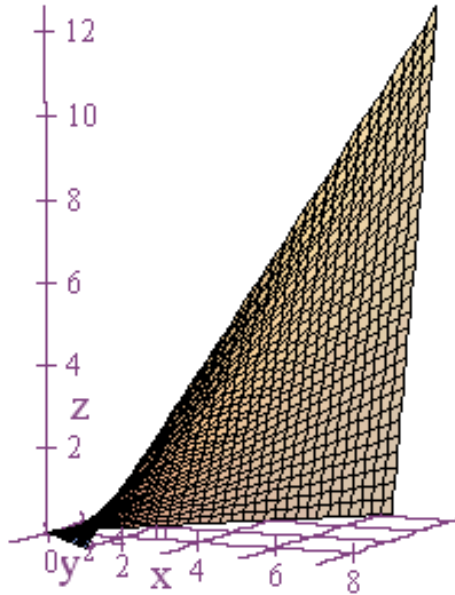

Now, however, suppose we scramble everything up by putting our variables in a row matrix, $(s + t \quad s - t \quad st)$, and multiplying on the right by the matrix

$$\begin{pmatrix} \cos(t+t) & -\sin(t) & \cos(st) \\ \sin(s+t) & 5 & -3 \\ 2 & \sin(s) & \cos(s-t) \end{pmatrix}, \text{ where } -3 \leq s \leq 3 \text{ and } -3 \leq t \leq 3.$$

Vector Transformations

Then the resulting graph looks like this. I call this one my Klingon bird of prey!

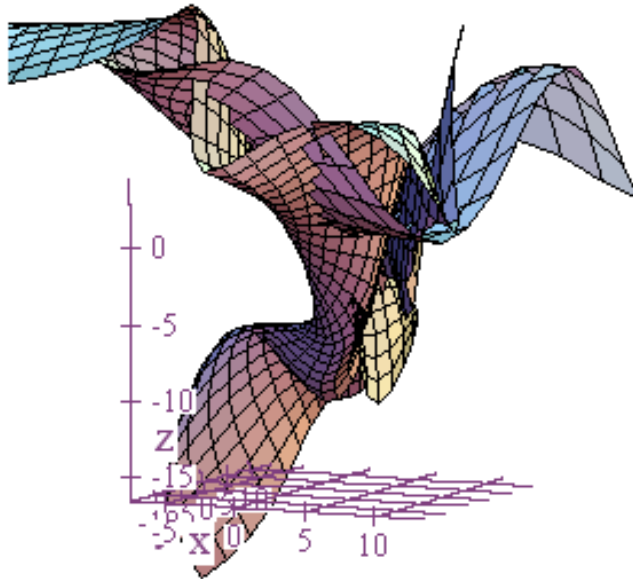

We can create a lot of interesting graphs by taking some standard parametric equations in two variables, and then multiplying on the right by a matrix to scramble them up. Then you can add another twist to the mix by deciding whether you want to treat the final result as rectangular, cylindrical, or spherical coordinates. This is where it really gets bizarre! Here are some more examples for you to ponder.

Vector Transformations

$$1. \quad (x, y, z)_{\text{rectangular}} = ([10 + 4 \cos s] \cos t, [10 + 4 \cos s] \sin t, 4 \sin s) \begin{pmatrix} 3 & 5 \sin s & \cos 3s \\ \sin s & 5 & \sin s \\ 2 \cos s & -\sin s & -8 \end{pmatrix}$$

$$0 \leq s \leq 2\pi$$

$$0 \leq t \leq 2\pi$$

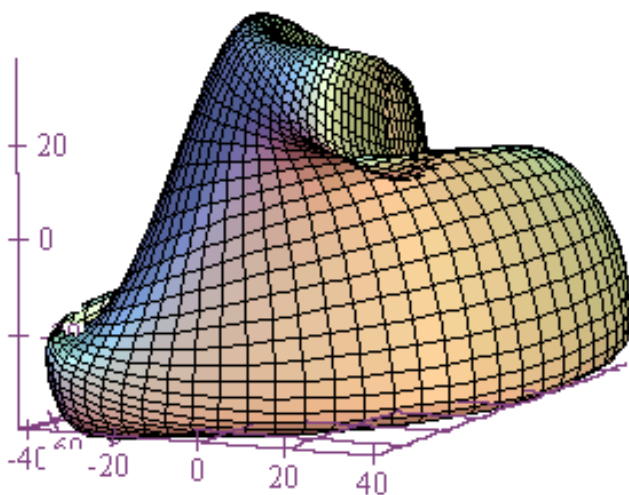

Vector Transformations

$$2. \quad (r, \theta, z)_{\text{cylindrical}} = (s+t, s-t, s^2-t^2) \begin{pmatrix} 3 & 5 \sin s & \cos 3s \\ \sin s & 5 & \sin s \\ 2 \cos s & -\sin s & -8 \end{pmatrix}$$

$$0 \leq s \leq 3\pi$$

$$0 \leq t \leq 3\pi$$

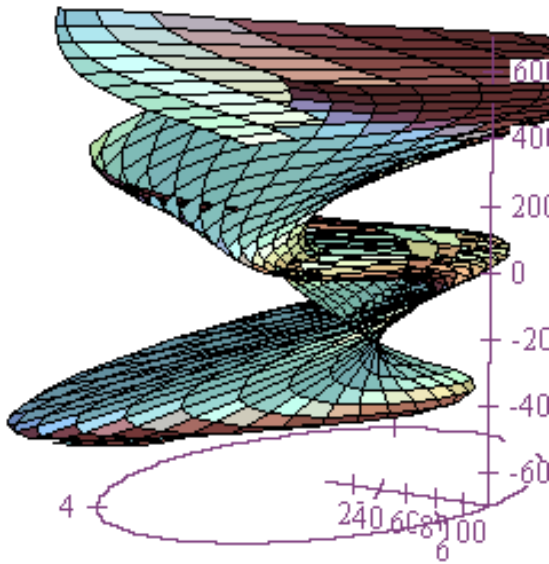

Vector Transformations

$$3. \quad (\rho, \theta, \varphi)_{\text{spherical}} = (\cos(s+t), \sin(st), \cos(s-t)) \begin{pmatrix} 3 & 5 \sin s & \cos 3s \\ \sin s & 5 & \sin s \\ 2 \cos s & -\sin s & -8 \end{pmatrix}$$

$$0 \leq s \leq 2\pi$$

$$0 \leq t \leq 2\pi$$

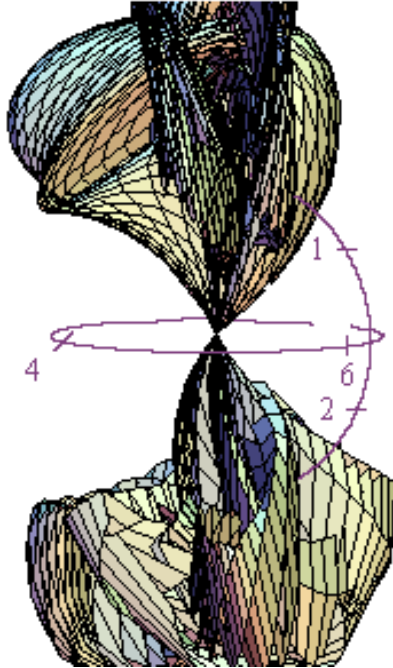

A now we'll close this chapter on vector transformations and parametric equations in two variables by presenting a variety of interesting graphs that mathematicians have discovered. Enjoy!

Vector Transformations

4. $x = t \cos s$
 $y = t \sin s$
 $z = \frac{t \cos 7s}{4}$
 $0 \leq s \leq 2\pi$
 $0 \leq t \leq 1$

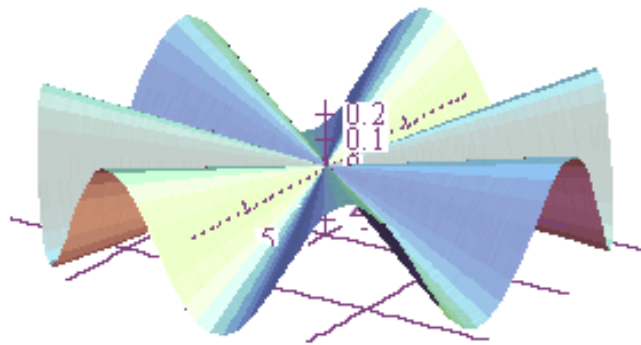

Vector Transformations

5. $x = t \cos s$
 $y = t \sin s$
 $z = 0.7s$
 $0 \leq s \leq 4\pi$
 $0 \leq t \leq 3$

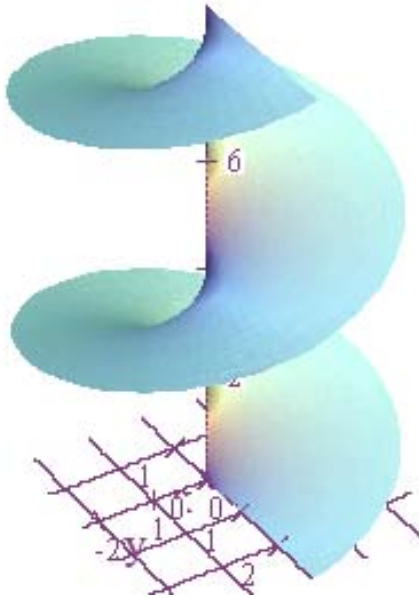

Vector Transformations

6. $x = t \cos s$
 $y = t \sin s$
 $z = \cos(-3s + t)$
 $0 \leq s \leq 2\pi$
 $0 \leq t \leq 5\pi$

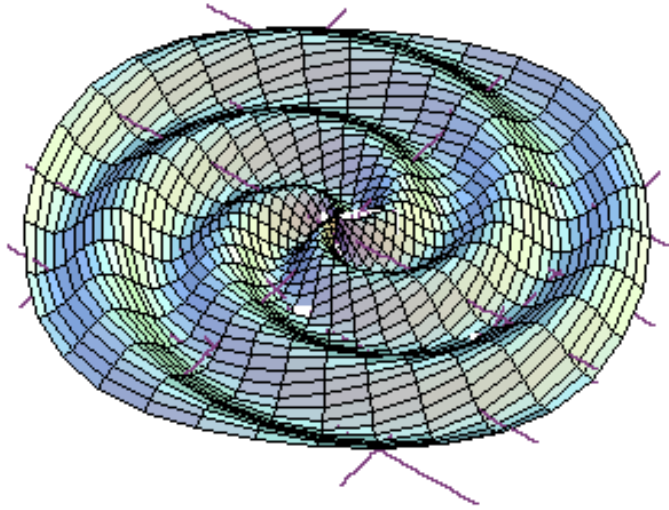

Vector Transformations

7. $x = 3\cos s \cos t$
 $y = 3\sin s \cos t$
 $z = 3\sin t + 2s$
 $0 \leq s \leq 2\pi$
 $-\pi \leq t \leq \pi$

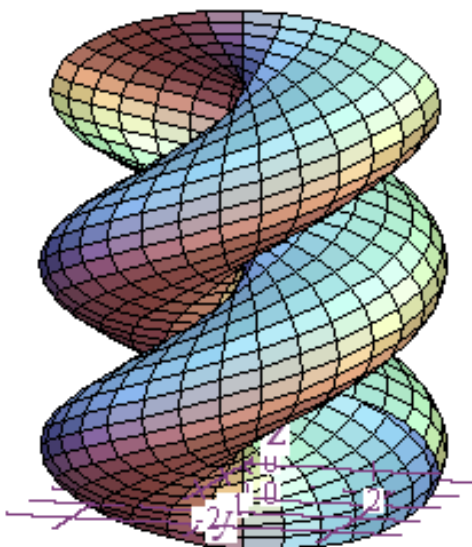

Vector Transformations

8. $x = \cos 2s \sin s \cos t$
 $y = \cos 2s \sin s \sin t$
 $z = \cos 2s \cos s$
 $0 \leq s \leq \pi$
 $0 \leq t \leq 2\pi$

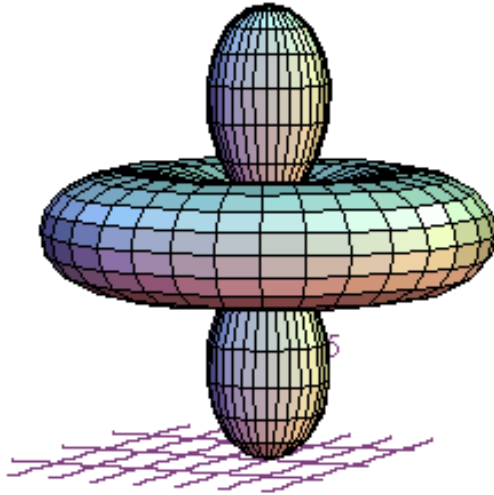

Vector Transformations

9. $x = s \cos s(3 + \cos t)$

$$y = s \sin s(3 + \cos t)$$

$$z = s \sin t - 7s$$

$$0 \leq s \leq 4\pi$$

$$0 \leq t \leq 2\pi$$

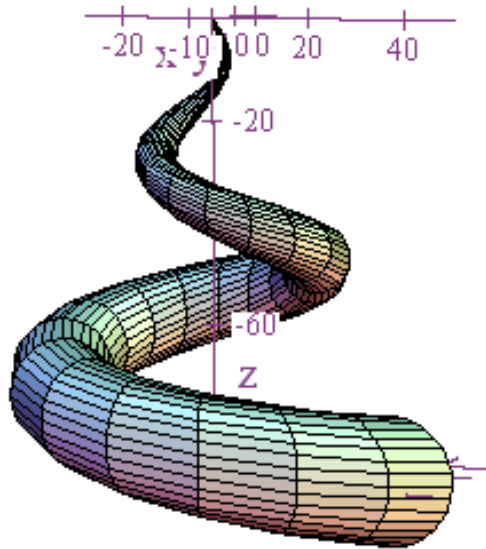

Vector Transformations

$$10. \quad x = \frac{t}{18} \sin s \cos t$$

$$y = \frac{t}{18} \sin s \sin t$$

$$z = \frac{t}{18} \cos s + \frac{t}{6}$$

$$0 \leq s \leq \pi$$

$$0 \leq t \leq 6\pi$$

